

Opt Lasers

Laser modules



Product Description:

The following description and pictures refer to whole Opt Lasers' laser modules line. Differences between modules are specified in the table in Technical data section. This manual concern following modules:

G520-120SM	120mW green laser module with a wavelength of 520nm
G520-1000SM	1000 mW green laser module with a wavelength of 520nm
R638-500SM	500 mW red laser module with a wavelength of 638 nm
R638-700SM	700 mW red laser module with a wavelength of 638 nm
B445-4000CM	4000 mW blue laser module with a wavelength of 445nm
B445-1600SM	1600 mW blue laser module with a wavelength of 445 nm

Microcontroller driving the laser module is responsible both for soft start of the laser diode and the regulation of temperature by using a thermocouple. In addition, in the event when adequate heat dissipation of the module is not ensured, the system protects the diode from overheating, and when the temperature of the diode exceeds 40 degrees Celsius, it prevents further current flow through the diode and goes into an alarm mode.

Opt Lasers

With a separate analogue part of the laser diode power supply, the laser is able to modulate the beam in accordance with the analogue input signal (0 - 5V) even at the frequency of up to 80 kHz.

The diode along with the entire optical system is mounted in a stylish housing which ensures both protection and cooling. To enable continuous work of the module, for example in a laser projector, it must be placed on an aluminum plate which allows for heat dissipation (thermal grease significantly improves the cooling of the module). Not only does this solution save space in the projector cabinet, but also reduces the level from which the beam is emitted. This is aimed at meeting the demands of customers who more often than not look for compact high-power modules.



The module is using a 4th version of a professional driver for laser diodes with a built-in digital temperature controller using the PID algorithm. Its size allows for mounting it in small devices such as compact laser projectors.

Opt Lasers

Technical Data:

Supply voltage (V)	7,5
Beam diameter of the output aperture (mm)	5
Estimated lifetime (hrs)	5000
The height of the beam from the base (mm)	30
Modulation voltage range (V)	0 - 5
Modulation type	Analog/TTL
Source	Laser diode
Operating mode	Multimode
Cooling	TEC cooled

Product name	G520-120SM	G520-1000SM	R638-500SM	R638-700SM	B445-1600SM	B445-4000CM
Product line	SM	SM	SM	SM	SM	CM
Wavelength (nm)	520	520	638	638	445	445
Output power (mW)	120	1000	500	700	1600	4000
Operating current (A)	3	5	3,5	3,5	5	17
Divergence - full angle (mrad)	1,6	3	2,5	5	2	2,5
Operating temperature (°C)	15-30	15-30	10-30	10-30	10-30	10-30

Opt Lasers

How to connect the laser module

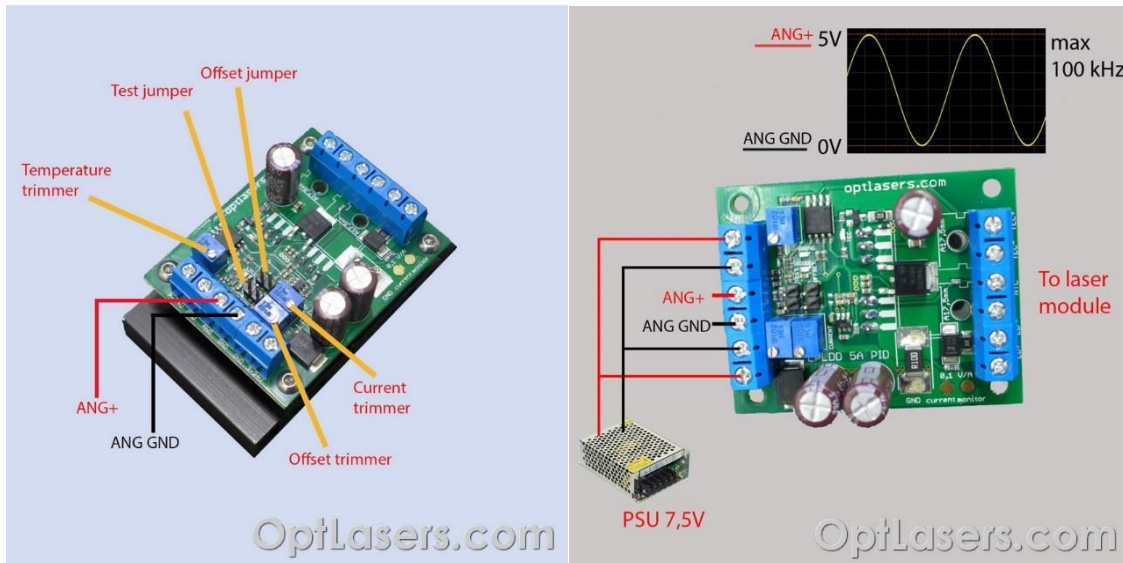

Recommended supply voltage is 7.5V. Higher voltage can lead to overheating of the driver. Nevertheless, power supply up to 12V may be used. Before turning on the power supply, make sure that all cables are connected correctly.

Connecting "Test jumper" allows to switch on the driver without an external analog signal. When Offset jumper is not connected, the Offset trimmer does not work. With the use of this TEC controller one can set the temperature in range of 0-40 degrees Celcius.

Note! When power supply is turned on or turned off, the signal ANG must be low.

Caution!

- Remember that it is not a toy.
- Laser radiation is dangerous even when scattered or reflected from any surface.
- Always use proper protection laser filter.
- Never point laser head at people or animals.
- Do not touch the beam, it may cause burns.
- Do not stare at the beam or the beam spot while the material is being cut.

Opt Lasers

Recommendations and requirements

The minimum diode input voltage should be higher than or equal to 7,5V.

Modulation input can be used as TTL input with its logic levels of 0V and 5V or as an analog input. Analog modulation means that by using 2,5 V on ANG input you get 50% of the output power, analogically by using 4 V you get 80% of the output power, etc.

You should be very careful not to cause short circuit between the + (VCC) of the power supply and - (GND) of the analog input, as a thin GND analog path can be irreparably damaged.

The MOSFET/MOSFETS must be isolated from the heatsink/plate with a silicon pad as well as a plastic sleeve. Short circuit between MOSFET and heatsink/plate can damage the driver and can be dangerous for the Laser Diode.

We recommend the use of power cables with cross-section of at least 0.5 mm².



Opt Lasers

Protection

The circuit responsible for powering a laser diode is protected against reversed polarity. High current Schottky diode of an extremely low forward voltage secures the laser diode against connecting reversed voltage with the aim of protecting frequently the most expensive part of the entire device - a laser diode. In turn, the low forward voltage does not cause excessive heat loss during normal operation.

The analog input is protected by a 5V1 Zener diode. On occasion there appears the voltage higher than 5V. Despite everything, this input should not be used with higher voltages.

A microcontroller ensures the proper operation of the entire system.

At start the microcontroller is checking the connection with a thermistor. If there is no thermistor used the WARNING LED is blinking but the driver is still working. If the connection with thermistor is lost during normal work, microcontroller turns off the laser diode supply circuit and does not allow for its further load. It also switches off the DIODE LED and switches on the WARNING LED. The TEC line is also switched off. The same situation happens when the thermistor reaches the temperature above 50 degrees Celsius.

The driver is fitted with a two-second softstart designed to protect the laser diode against switch-on effects.

Opt Lasers

Dimension

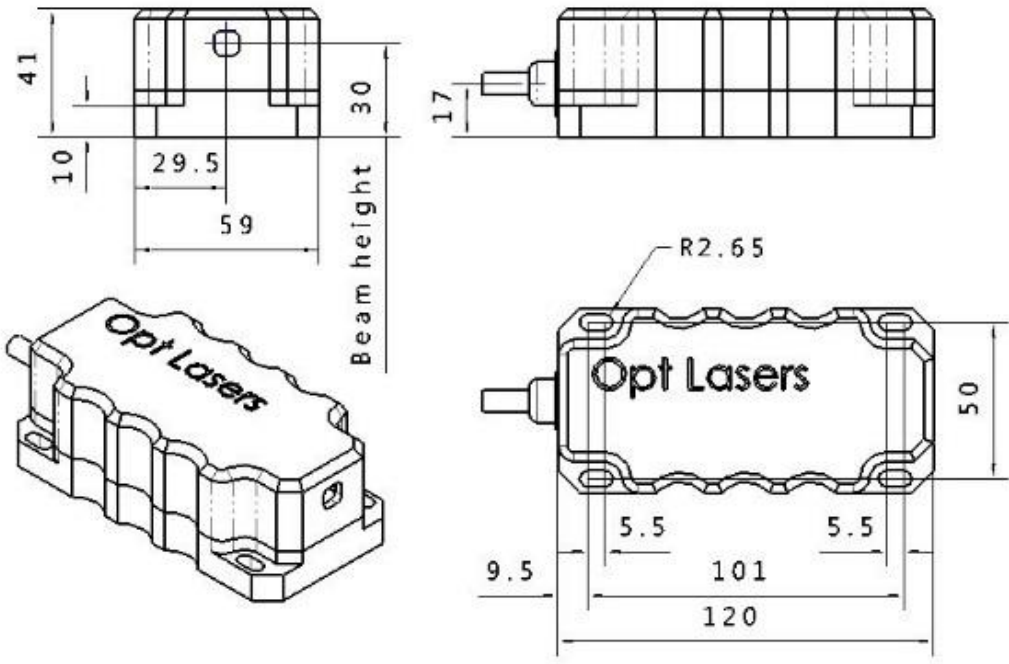

OptLasers.com